

WATER BASED PRESSURE SENSITIVE ADHESIVE DRYING

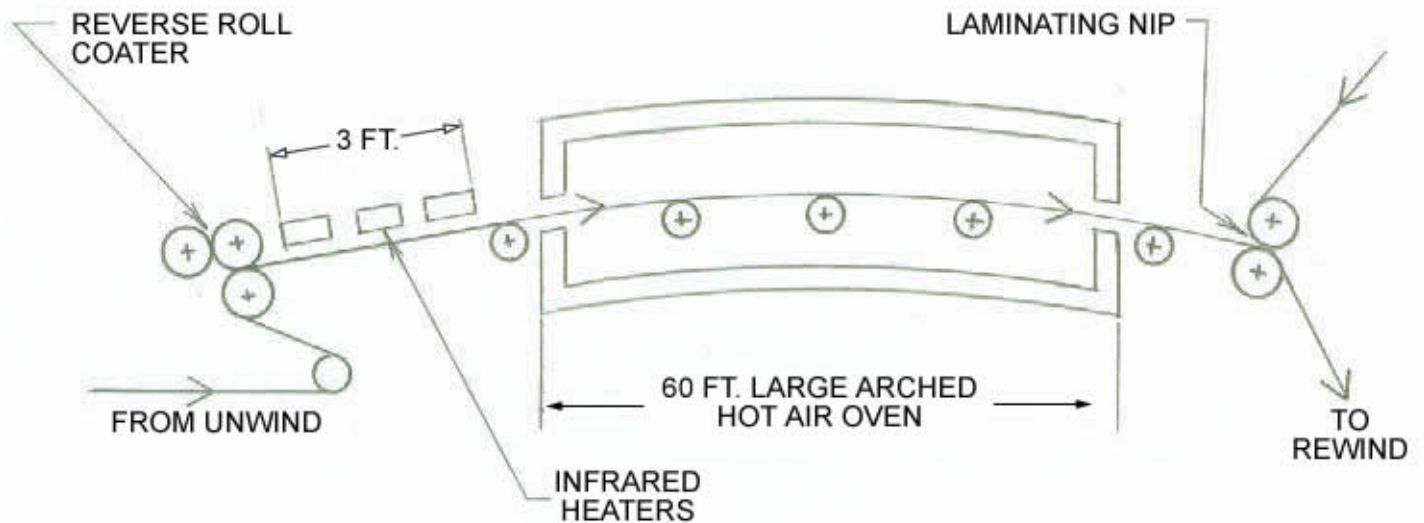

PROCESS:	Dry Water Based Pressure Sensitive Adhesive on Release Liner
PROBLEM:	To Increase Line Speed on the Existing Line, when Space is Limited
SPECIFICATIONS:	Line Speed 27 fpm with Existing Oven Coating 50% Solids, 50% Water Application 8 mils Wet; 4 mils Dry Coating Weight 3.6-4.0 oz/sq. yd. Web Width 65"
SOLUTION:	Install a 3 ft. long by 72" wide Infrared Heater Bank after the Reverse Roll Coater and before the Oven
RESULT:	Line Speed Increased to 48 fpm – a 77% Gain